



I TIMOTHY 4:7

But *refuse* profane and old wives' fables, and
exercise (gymnazo - train) thyself rather unto *godliness*

THE BEST EXERCISE FOR CHRISTIANS

I TIMOTHY 4:6-10

*To my disciple
 – preserve, protect, pass!*

I TIMOTHY 4

- Pursue true godliness found in Jesus Christ

“CHRISTIAN” SUPERSTITION

- **Forbidding** to marry, and
- **Commanding to abstain** from meats

I TIMOTHY 4

Pursue true godliness found in Jesus Christ

- Don't buy into a false brand of godliness
 - ~ It's the devil's lie!
 - ~ It restricts God-given freedom!

I TIMOTHY 4: 1-5

- I. Check practices advocated against God's Word
- II. Ask God for wisdom to discern right choices

I TIMOTHY 4:6

If **thou put the brethren in remembrance of these things**, thou shalt be a **good minister of Jesus Christ**, ...

I TIMOTHY 4

Pursue true godliness found in Jesus Christ

- Train ourselves to **apply** Biblical truth

I TIMOTHY 4:6

If thou put the brethren in remembrance of these things, thou shalt be a good minister of Jesus Christ, **nourished up in the words of faith and of good doctrine, whereunto thou hast attained.**

I TIMOTHY 4:7

But *refuse* profane and old wives' fables, and **exercise (gymnazo - train) thyself** rather unto **godliness**

I TIMOTHY 4

Pursue true godliness found in Jesus Christ

- Train ourselves to **apply** Biblical truth

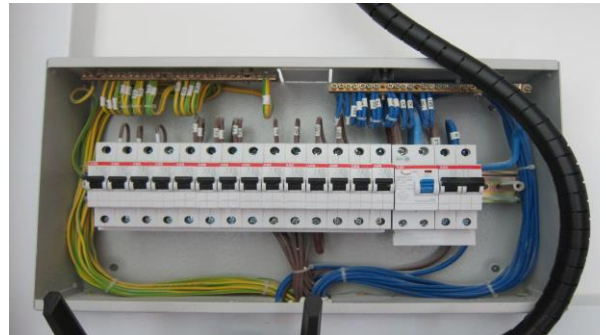
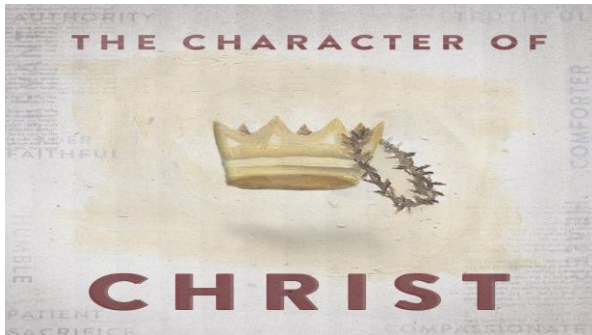

I TIMOTHY 4

Pursue true godliness found in Jesus Christ

- Train ourselves to apply Biblical truth
- ~ It's beneficial for eternity & worthy of priority

I TIMOTHY 4:8

For bodily exercise profiteth little:

but **godliness** is profitable unto all things,
having promise of the life that now is,
and of that which is to come...

I TIMOTHY 4

Pursue true godliness found in Jesus Christ

- Train ourselves to apply Biblical truth
- ~ It's **beneficial for eternity** & worthy of priority

I TIMOTHY 4:9

This is a faithful saying and worthy of all acceptance.

I TIMOTHY 4

Pursue true godliness found in Jesus Christ

- Train ourselves to apply Biblical truth
- ~ It's beneficial for eternity & **worthy of priority**



I TIMOTHY 4

Pursue true godliness found in Jesus Christ

- Train ourselves to apply Biblical truth
- ~ It's beneficial for eternity & worthy of priority
- ~ It's **motivated by hope in Jesus Christ**

I TIMOTHY 4:10

For therefore we both labour (*toil to point of exhaustion*) and suffer reproach (*agonize*), because we trust in the living God, who is the Saviour of all men, specially of those that believe.

I TIMOTHY 4:10

For therefore we both labour (*toil to point of exhaustion*) and suffer reproach (*agonize*), because we trust in the living God, **who is the Saviour of all men**, specially of those that believe.

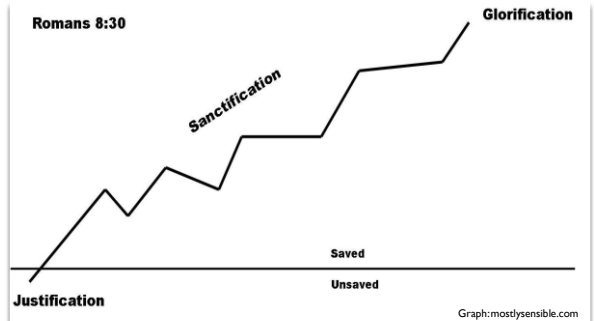

PHILIPPIANS 1:6

Being confident of this very thing, that He which hath begun a good work in you will perform it until the day of Jesus Christ.

TITUS 2:11-13

For **the grace of God** that bringeth salvation hath appeared to all men,

Teaching us that, denying ungodliness and worldly lusts, we should live soberly, righteously, and godly, in this present world;

Looking for that blessed hope, and the glorious appearing of the great God and our Saviour Jesus Christ ...

I TIMOTHY 4

Pursue true godliness found in Jesus Christ

- Train ourselves to **apply** Biblical truth
- ~ It's beneficial for eternity & worthy of priority
- ~ It's motivated by hope in Jesus Christ

FRUIT OF THE SPIRIT

love,
joy,
peace,
patience,
kindness,
goodness,
faithfulness,
gentleness,
and self-control



Galatians 5:22-23

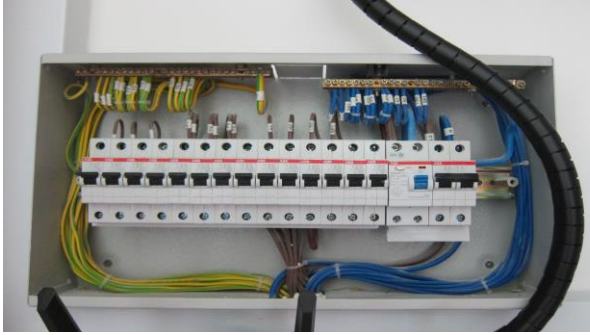

THE BEST EXERCISE FOR CHRISTIANS

I TIMOTHY 4:6-10

*To my disciple
— preserve, protect, pass!*